

- NOTES:**
1. THIS SUSPENSION IS FOR LOCKED STEERING AXLE ONLY. IF THE STEERING AXLE IS USED, IT IS THE RESPONSIBILITY OF THE CUSTOMER TO ACCOUNT FOR 3 TO 5 DEGREE CASTER ANGLE AT THE AXLE DOWN RIDE HEIGHT AND THAT A STEERING DAMPNER KIT IS USED.
 2. A CROSS BRACE BETWEEN SUSPENSION HANGERS IS NOT REQUIRED IF THE FRAME CROSSMEMBERS ARE LOCATED. ABOVE THE AIR SPRING MOUNTING PLATES AND THE HANGERS
 3. CUSTOMER SUPPLIED X-MEMBER TO BE WELDED OR BOLTED ONTO SUSPENSION HANGERS.

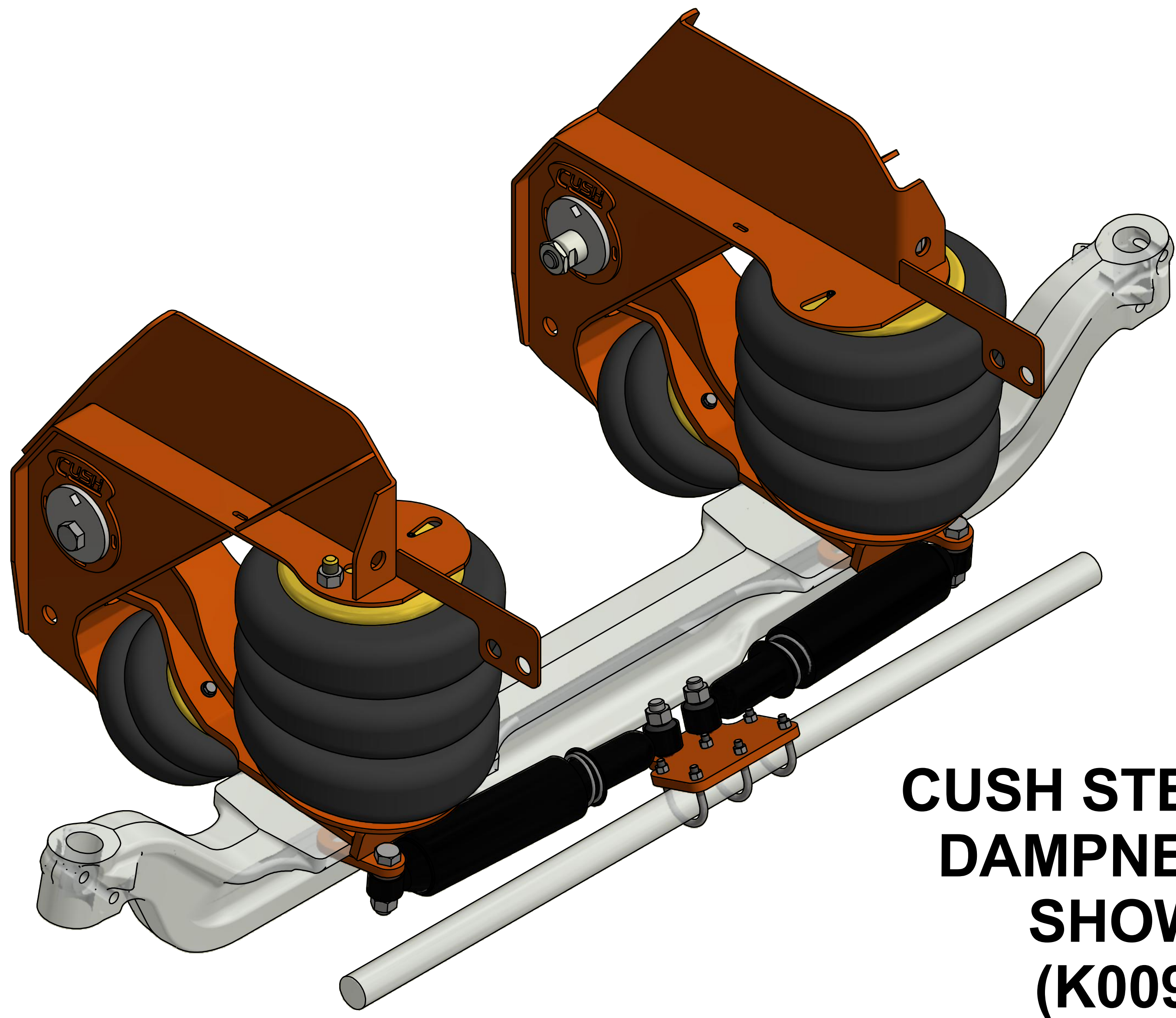

CUSH STEERING DAMPNER KIT SHOWN (K0094)

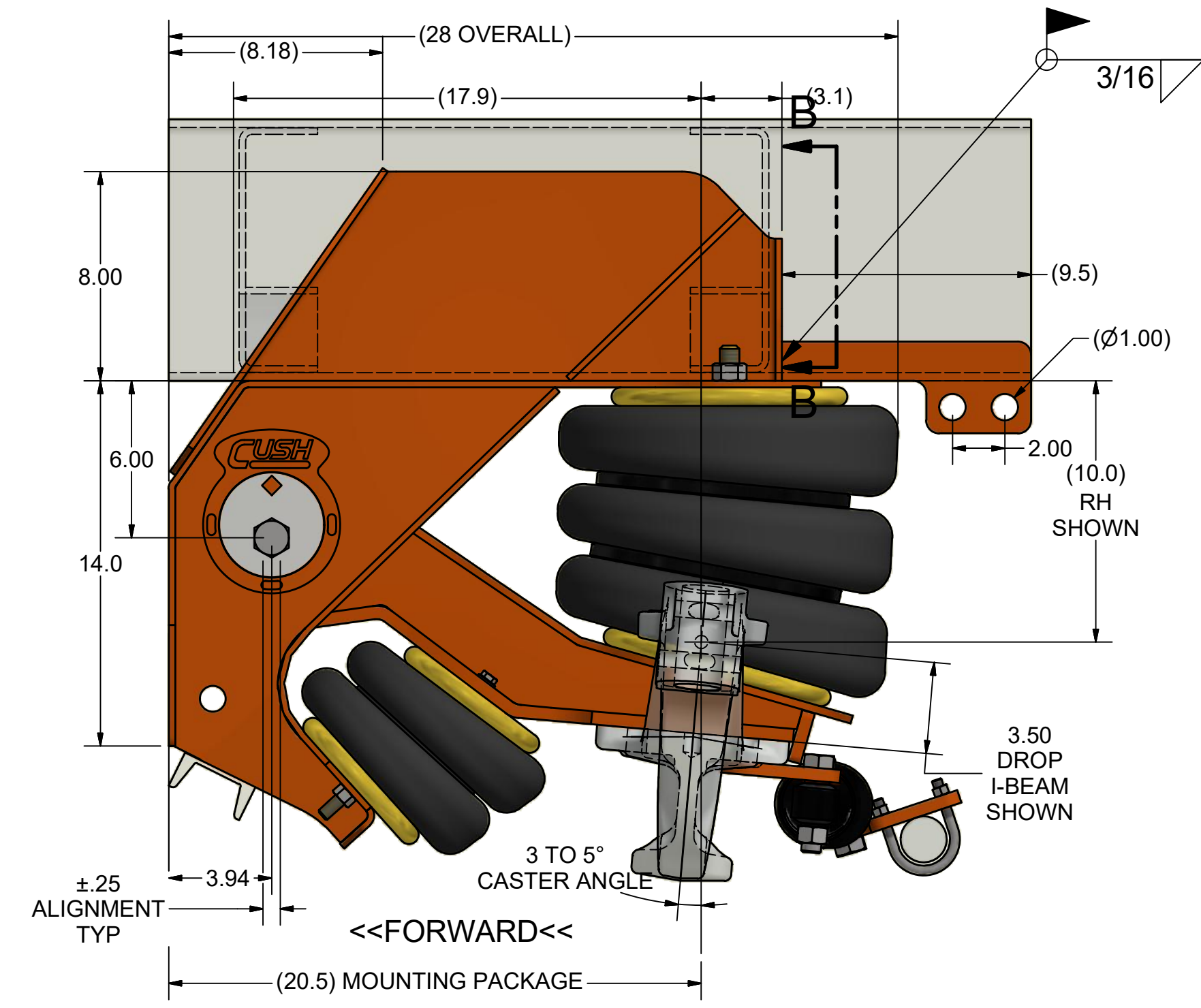
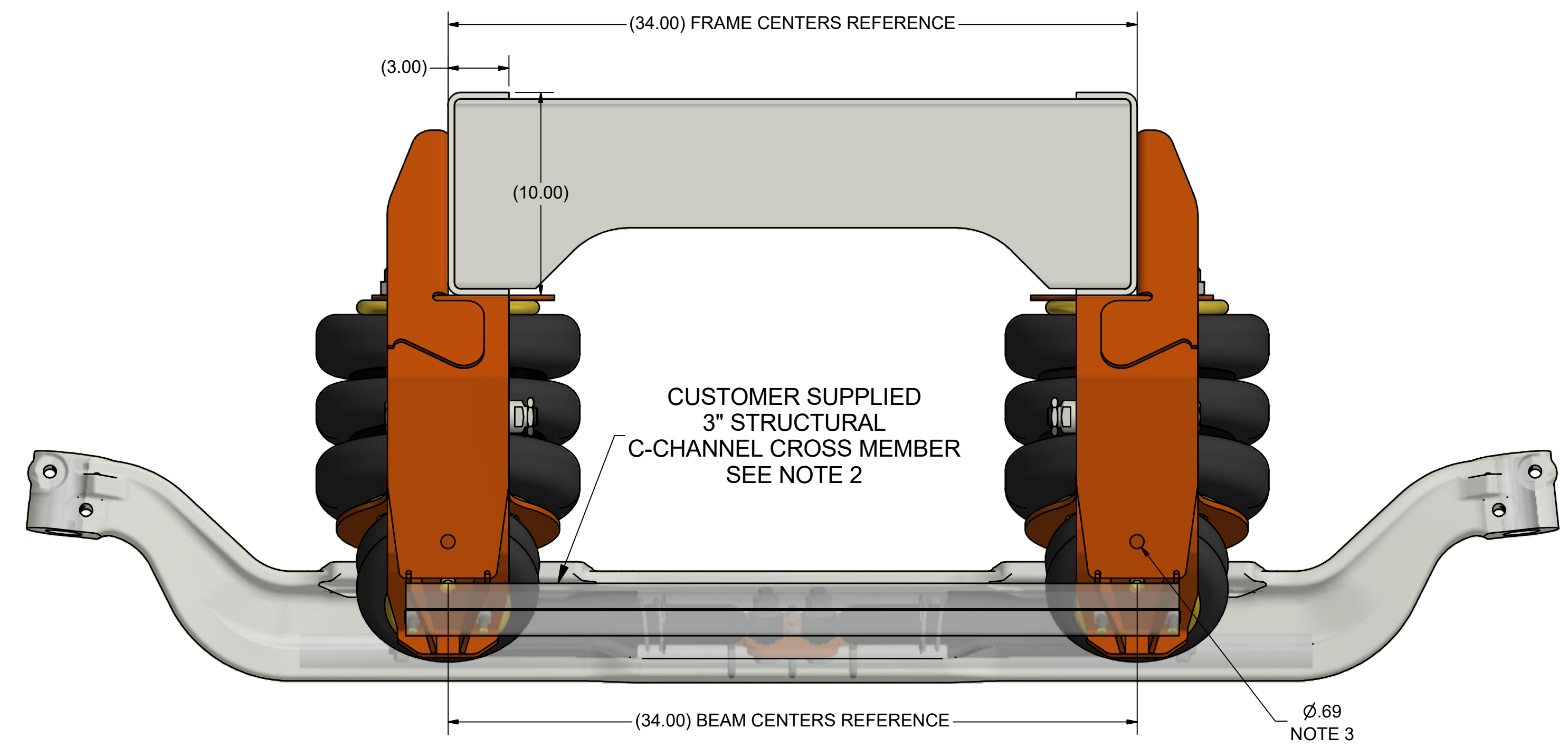
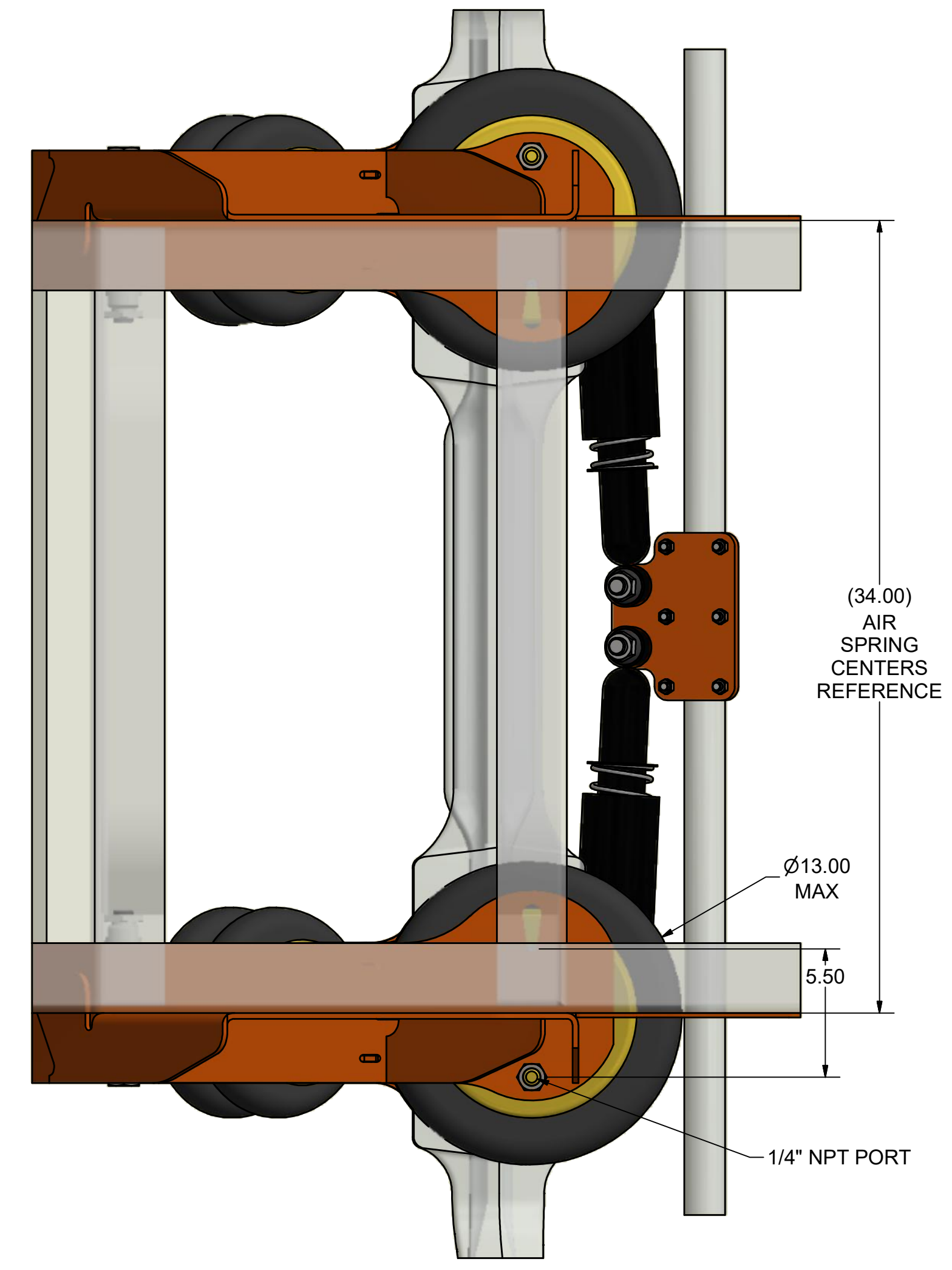

CUSTOMER TO LOCATE AND WELD BRACKET TO HANGER

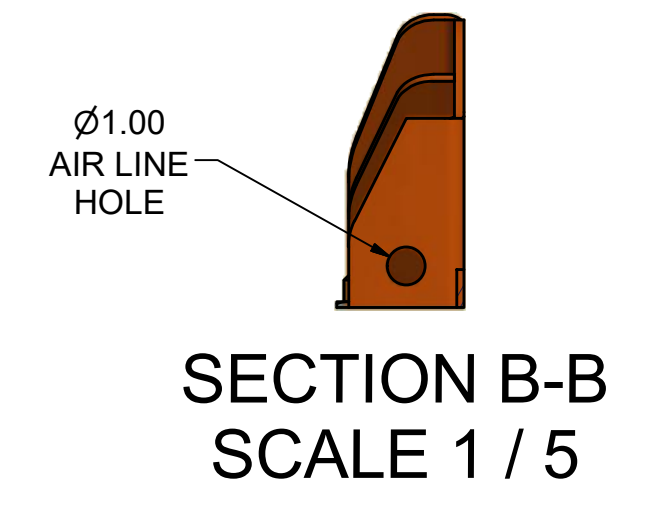

DCN#	REV	REVISION DESCRIPTION	DATE	BY	CHK	APP
DRAFTSMAN: DWalk	07/2017	TITLE:				
CHECKED: CHK		CUSH AUXILLARY I-BEAM AXLE				
RELEASED: APP		13K SUSP WEIGHT RATING				
WEIGHT: N/A		9-11" RIDE HEIGHT				
MATERIAL:		BOLT-ON RAIL HANGER				
All of the Information shown herein is the intellectual property of Cush Corp and is submitted only on a confidential basis. The recipient agrees that no disclosure of this information will be made to a third party without written consent of Cush Corp.		TOLERANCE UNLESS OTHERWISE STATED: XX = +/- .002 FRACTIONS = +/- 1/16 XXX = +/- .001 ANGLES = +/- 1°		Nixa, MO, USA PHONE: 417-724-1239 www.cushcorp.com		
PROJECT NO:	SHEET:	SCALE:	REV:	DRAWING(PART) NO:		
17046	1 OF 6	A-SIZE: NTS B-SIZE: 1/X D-SIZE: 1/4	-	CX245is-A		