

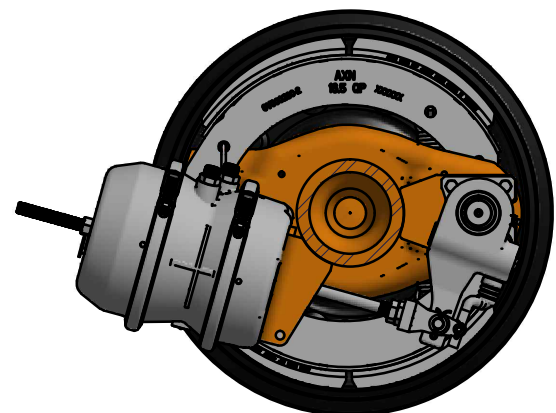

Note:
Chambers under
w/ ports on top

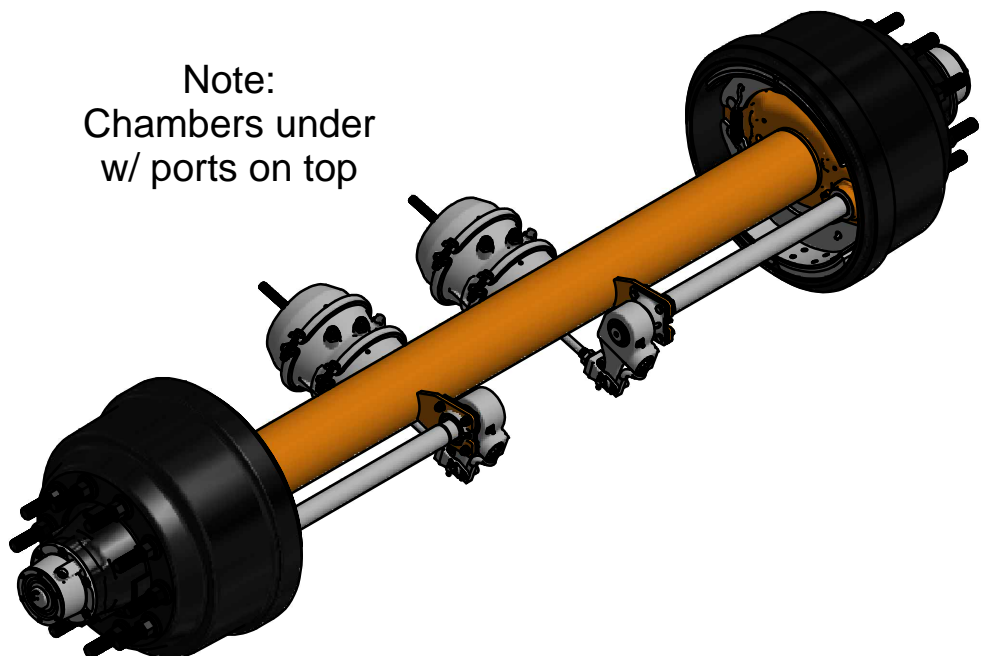

SECTION B-B
SCALE 1/8

H03A is ABS axle with medium 18" sensor wire.
H03N is NonABS axle but with tone ring.

Options	Cush Axle Model Number	H03-A	H03-N
	ABS Sensor (With-A or Without-N)	ABS With Wabco 918" LONG P/N 441 032 808 0 or 441 032 154 0	Non-ABS Without (but w/same specs)
	Axle Track (71.5", 77.5")	76.5"	All below specs the same
	Wheel Seals (Oil or Grease)	Oil	
Model ID	Wheel-end Lube: Chevron RPM Universal 80W-90 Oil Chevron Synthetic 75W-90 Oil Grease-Chevron Stamples EP2 Grease-Chevron Delo Semi Fluid	Chevron RPM Universal 80W-90 Oil	
	Brake Orientation	90 Deg Rear (Chambers under-ports up)	
	Cush Model (see Cush Model ID chart)	Hxx	
	Axle Diameter (5", 127mm, 5.75", 146mm-BDA)	5" (127mm)	
	Axle Wall Thickness/Nom Beam Rating (8.5mm_BDA, 10mm_BDA, 12mm_22.5K, 15mm_25K, 19mm_30K)	3/4" (19mm)_30K	
	Camshaft Length (Special-Intimed, long) or (C11-0301_524&13)	Special - long	
	Spindle Type (T-Tapered(N/Q) or P-Parallel)	T-Tapered	
	Bearing Manufacturer - Cup	STEMCO	
	Bearing Manufacturer - Cone	STEMCO	
	ASA Manufacturer and Type or P/N	BTC, 5.5" Automatic (P/N ASB107105)	
Brake	Brake Chamber Type	BTC Type 30/30 (P/N T3030EBS)	
	Brake Friction	AXN R23	
<Specs>	Brake Size & Type	16.5 x 7	
	Camber (Yes or No)	No	
	Cam Enclosures (Yes or No)	No	
	Dust Shields (Yes or No)	No	
	Axle Type (Straight, Drop, Crank)	Straight	
	Spindle Nut Type, No of Cotter Pin Holes	Double Nut, 0	
	ABS Block (yes or no)	Yes	
	Spindle Plug Type	Vented	
	Spindle Plug Depth	Meritor Type	
	Brake Type - Q or Q Plus	Q Plus (4707Q)	
	Spider Type	Stamped	
	Camshaft Bushing Type	Bi-metal	
	Camshaft Splines	28	
	Brake Chamber Bracket Style	C-channel	
	Axle ID Tag	CUSH or AXN Heavy Duty	
	Axle Beam Coating (Color & Type)	Black E-Coat	
	Brake Shoe Type (Fuwa Std or Lightweight)	AXN Lightweight	
	Brake Shoe Coating (Color & Type)	Black E-Coat	
	Axle Interior Clean and Dry (Yes or No)	Yes	
	Axle Interior Coated (Yes or No)	No	
	Friction Markings per AXN Specification (Yes or No)	Yes	
	Top Center Hole (Yes or No)	No	
	Integrated Bracket for Haldex ASA (Y/N)	Yes	
	Wheel-ends (type)	10 Hole, 11.25"BC Hub Pilot, Outboard Mount	
	Hub Manufacturer & Type	Fuwa p/n	
	Drum Manufacturer & Type	Fuwa p/n	
	Hub Cap Type (oil or grease)	6 Hole, Stemco	
	Hub Cap Gasket	Stemco (P/N 330-3009)	
Hub Alert	N/A		
Brake Stroke Indicator	N/A		
Seal Manufacturer	Stemco Guardian (P/N 307-0743)		
Stud Length (wheel type)	Dual Aluminum		
Wheel Nuts	20 Wheel nuts		
ABS Tone Ring (Not including Sensor)	With Tone Ring (see sensor spec)		

DCN#	REV	REVISION DESCRIPTION	DATE	BY	CHK	APP	
DRAFTSMAN: DJW	8/4/2014	Fully Dressed HD 25K Axle 16.5" x 7" Brakes 76.5" Track, oil, 5"x 3/4" wall, long cams, tapered spindle, 30/30, 5.5" Autoslacks, rear cam-chambers under-ports top, Stemco Bearings					
CHECKED:							
RELEASED:							
WEIGHT: N/A							
MATERIAL:		TOLERANCE UNLESS OTHERWISE STATED: .XX = +/- .062 FRACTIONS = +/- 1/16 .XXX = +/- .031 ANGLES = +/- 1°					
All of the Information shown herein is the intellectual property of Cush Corp and is submitted only on a confidential basis. The recipient agrees that no disclosure of this information will be made to a third party without written consent of Cush Corp.		PROJECT NO:	SHEET:	SCALE:	REV:	PART/DRAWING NO:	
		14090	1 OF 1	A-SIZE: NTS B-SIZE: 1/16 D-SIZE: 1/X	-	Axle_H03(A/N)	
						Nixa, MO. USA PHONE: 417-724-1239 www.cushcorp.com	