

RIDE HEIGHT VARIABLES

"R"	"UP"	"DN"
4.5	2.0	5.5
5.0	2.5	5.0
5.5	3.0	4.5
*6.0	3.5**	4.0
6.5	4.0	3.5
7.0	4.5	3.0

*GEOMETRY SHOWN
**Minimum liftable up travel

CUSH GENERAL INSTALLATION NOTES, SEE CUSH SERVICE/INSTALLATION MANUAL

INSTALLATION DISCLAIMER NOTES:
 1) It is important that the proper Cush suspension is chosen for the trailer application. The following criteria must be considered when selecting a suspension: required suspension capacity, loaded frame-to-ground measurement, ride height, axle travel, axle spacing, and axle GAWR.
 2) It is the responsibility of the installer to determine the correct location of the suspension in order to provide the proper trailer load distribution. The gross axle weight rating (GAWR) of each axle must not exceed the rated capacity of any of the components involved. The suspension capacity ratings are for suspension components and axle beam only.
 3) Required cross member locations may be shown. Actual size and shape may vary per trailer design. It is the responsibility of the suspension installer to ensure structural adequacy of the trailer frame and related cross members. Verify that the actual trailer cross member locations correspond with those specified on the suspension drawing.
 4) It is the responsibility of the suspension installer to read the instructions on all the drawing sheets thoroughly before proceeding with a suspension installation.
CUSTOMER TORQUE INSTRUCTIONS:
 1) *DUAL RATE PIVOT BUSHING JOINT SNUG FROM FACTORY. CUSTOMER TO TORQUE THIS JOINT TO SPECIFICATION AFTER AXLE ALIGNMENT.
 2) It is the customer's responsibility to check and tighten fasteners to specified torque at installation, after the suspension has been in operation for 3000 miles, and at suspension inspection cycles. Failure to do so can result in loss of warranty.
 3) Torque values given are specified for the fasteners in the condition supplied by Cush Corporation. DO NOT APPLY ANY ADDITIONAL LUBRICANTS.
 4) CAUTION: Fasteners should never be reused if removed or loss of clamp load occurs. For proper joint clamping contact Cush for replacement fasteners.
 5) CAUTION: Over-torquing fasteners could result in material failure.

Customer to torque all fasteners!				(Ft*Lbs)		(Nm)	
General Fastener Torque Specs	Size	Thread	Grade	Min.	Max.	Min	Max.
Air Spring Mount Bolt	3/8	16-UNC	5/B	25	35	34	47
Air Spring Bottom Mount Nut	1/2	13-UNC	5/B	25	35	34	47
Air Spring Bottom Mount Bolt	1/2	13-UNC	5/B	40	50	54	68
TRAC-ALIGN Rack Lock Bolt	1/2	13-UNC	5/B	25	35	34	47
Brake Chamber Mounting Nut (10K) U-Bolt Nut	5/8	11-UNC	5/B	100	110	136	149
Air Spring Top Mount Nut	3/4	10-UNC	8/C	180	210	244	285
Nyloc Jam Nut	3/4	10-UNF	5/B	40	50	54	68
Shock Mount Nut/Bolt	3/4	10-UNC	A/B	80	100	108	136
(15K) U-Bolt Nut / Pivot Bolt	3/4	10-UNC	8/C	210	235	285	319
(25K) U-Bolt Nut	7/8	14-UNF	8/C	475	525	644	712
Pivot Nut (SecureLok/Securex)	7/8	9-UNC	8/C	550	600	746	813

General Application Dimension Variables - Installation Clearance Notes Supersede all Common Variables Shown						
*B" Ref. Suspension Beam(Hanger) Centers	34	35	40	41	40	39
*S" Ref. Air Spring Centers (2" inset/side)	30	31	36	37	36	35
*T" Ref. Axle Track	71.5"	71.5"	76.5"	77.5"	77.5"	77.5"
*C" Approx. Chamber Centers for Brake	9.75	9.75	14.75	15.75	15.75	15.75
*T" Ref. Inside of Tires Min (Hanger Style)	46.5	46.5	51.5	52.5	52.5	52.5

Installation Clearance Notes
 1) 0.75" minimum clearance must be maintained around air spring when it is at maximum diameter.
 2) It is the responsibility of the installer to ensure that proper clearances exist at the tires: 1" minimum clearance required between top of tire and bottom of trailer structure when axle is at full jounce, 2" minimum clearance required between inside of tire and trailer frame structure for lateral movement, and there should be ample fore and aft clearances. 0.25" clearance is recommended between suspension beam and brake s-cam shaft.

AXLE WELDING NOTES. See Cush Procedure A0001:
WARNING: Review Cush Recommended Steel Welding Procedures
 1) Suspension components and their mating parts must be at a minimum temperature of 60°F(15.5°C) and free from moisture, dirt, scale, paint, grease, and other contaminants.
 2) For the best axle to beam weld joint use the following wire. Axle Weld Wire: AWS ER70S-6
 3) Create the root pass to connect the axle to the trailing arm beam. Hit the axle seat tabs down to the axle to give you parent metal for pass 2 and 3. Finished axle weld should be a multi-pass 1/2" weld.
ORIGINAL-INSTALLATION INSPECTION NOTES, verify that:
 1) The installation clearance requirements have been met.
 2) The axles have been aligned properly.
 3) The suspension frame bracketry and air spring plate welds have been properly completed per specifications.
 4) All suspension bolt torques are to Cush specifications.
 5) The suspension ride height is set properly.
 6) The suspension can articulate freely through its entire travel and adequate component clearances have been provided.
INSPECTION: 30-DAY, 90-DAY, & at every brake lining change. 1) Check installation clearance requirements. 2) Check for any signs of wear or component interferences. 3) Check suspension attachment welds for signs of problems. 4) Check that all bolts are in place and securely torqued. 5) Check pivot bushings & clamping connections for problems. 6) Check that the trailer is level. 7) Check tire wear that might indicate an alignment problem.

INSTALLATION NOTES:
 1) Measure trailing arm centers and track to verify your requirements.
 2) DO NOT APPLY undercoating to the suspension until after completing the alignment. Undercoating will effect clamp load of the pivot connection fastener and can damage the hardware.
 3) Mount hangers onto trailer frame per suspension drawing sheets.
 4) Place plastic washers on both sides of bush inner metal and insert spacer collars into bush inner sleeve.
 5) Measure for fitup then mount Cushride trailing arm/axle assembly into suspension hangers.
NOTE: If the assembly fits tightly, it may be necessary to spread the mounting. DO NOT GRIND material from suspension components.
 6) Place "Align" gear washer, with indicator in neutral position, and insert pivot bolt/washer
 7) Mount pivot washer/nut and torque joint for a snug fit.
 8) Adjust "Align" for proper axle track alignment.
 9) Torque bushing pivot bolts per Cush torque instructions.
NOTE: Failure to follow the procedures in the Cush Service and installation manual and/or properly torque the pivot fasteners at this time can result in a failed pivot connection and a loss of warranty coverage!
 10) Install air springs and shocks per suspension installation manual and drawing sheets.

INSTALLATION OF "TRAC-ALIGN" NOTES:
OVERVIEW: The "Trac-Align" pivot joint features outside eccentric cam gear washer that cover the alignment slot. The "Trac-Align" was designed to give our customers extra pivot integrity with the addition of the optional locking rack and a more familiar alignment means with the use of an eccentric cam adjustment. The "Trac-Align" also has bearing washer with tabs for use with a Cush axle-welding stand to have a more precise fixturing of the suspension and axle at factory or customer integration. **CAUTION:** DO NOT APPLY undercoating to the "Cush-Align" area until after alignment and torque of the pivot bolt.

- If you have the optional rack lock plate, loosen the rack lock bolts to allow eccentric cam movement.
- The eccentric cam gear should always have the 1/2" square hole to the top.
- Set the alignment gear indicator tab at 6 o'clock, the neutral position. Snug the rack lock bolts and pivot bolts of the "Trac-Align" to be tight enough to hold the joint together but loose enough to permit use of the eccentric cam adjustment. Be sure that the eccentric cam plate is clamped down flush against the hanger side and is not riding up the grounding nuts/bars.
- For adjustment use a breaker bar in the 1/2" square hole or use a box wrench on the lower eccentric cam gear nut.
- The "Trac-Align" gives you 3/8" pivot movement fore and aft per hanger side. (see Installation Manual)
- To align the axle, rotate the alignment gear of one side of the suspension to get the axle aligned. If needed, go to the other side of the suspension and rotate the alignment gear in the opposite direction to fully align the axle.
- After alignment, clamp the joint per Cush torque specifications. After alignment, the suspension installer can weld the outside washer to the hanger side with 1/2" welds to prevent tampering & for off-road applications.

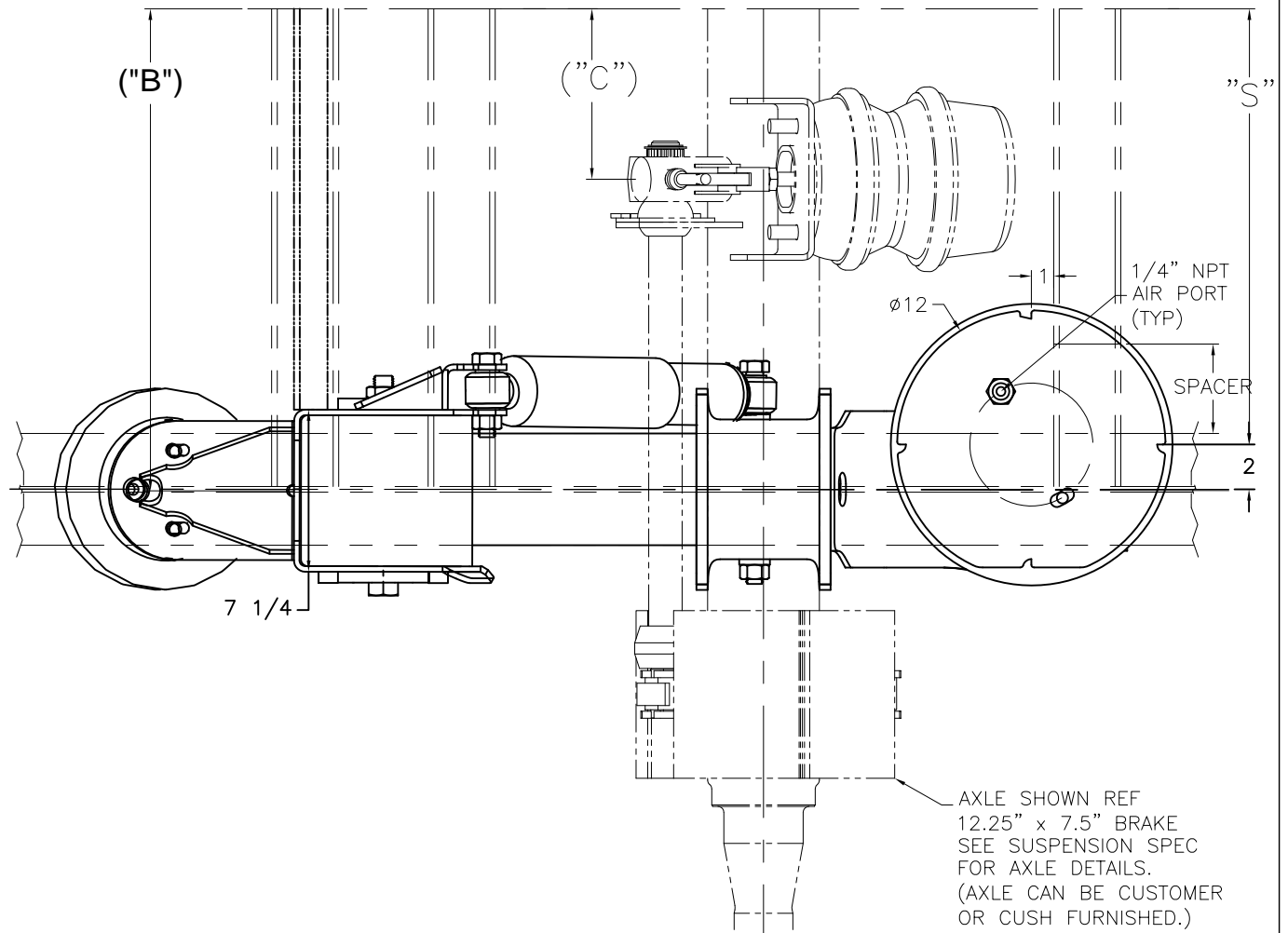

Cush Trailer Suspension	
Model: CLC-25-005/L	
Load/Air Spring PSI @ 6" Ride Height	
Load Per Axle* (lbs.)	Req'd PSI
25,450	100
22,900	90
20,350	80
17,850	70
15,300	60
12,850	50
10,350	40
*Approximate Values, Calibrate/Appl. (Air Spring Part No. C0079) Decal Part No: C0174-5	

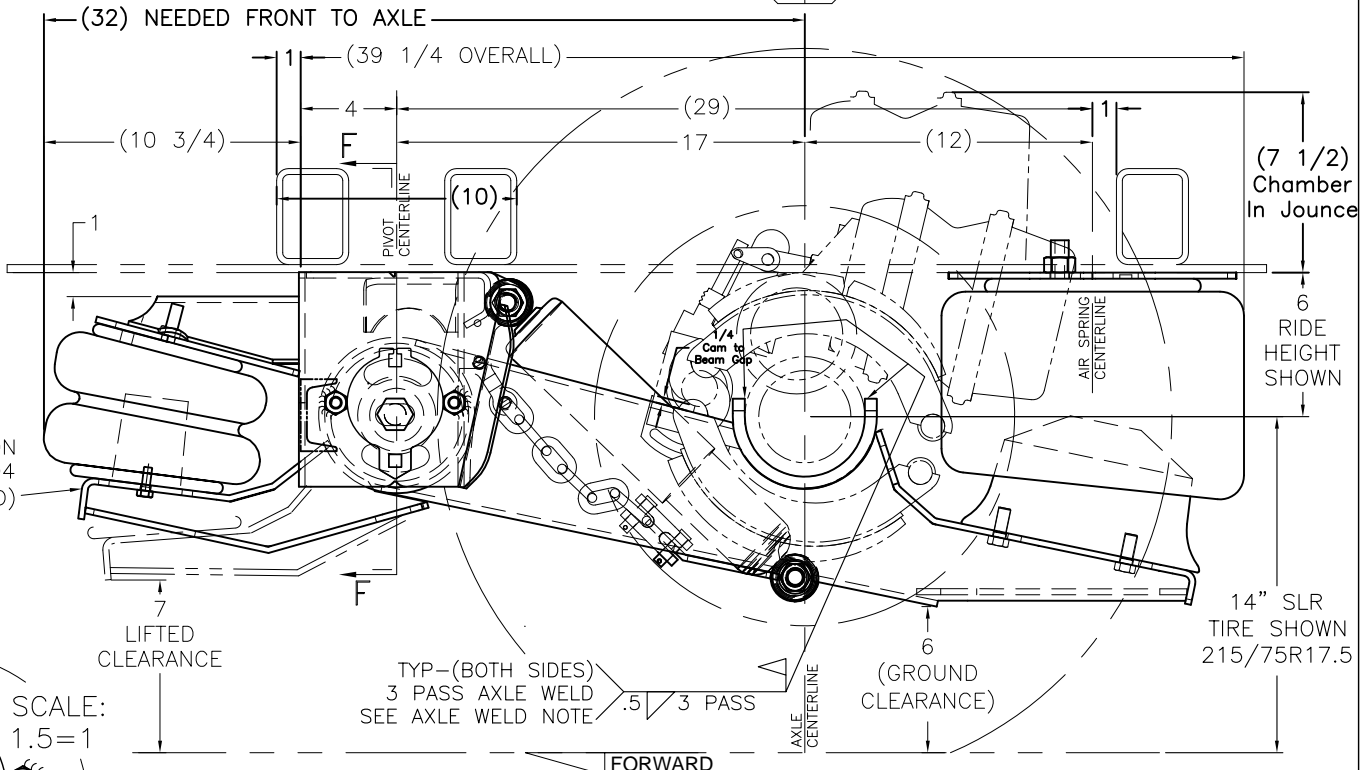

DRAFTSMAN: BGA 2/03/2010	APPLICATION INSTALLATION SHEET	CUSH CORP Nixa, MO, USA www.cushcorp.com
CHECKED: -	Cush Weld-on Compac-Trac 25,000# Gross Suspension Weight Rating w/ Lift Option SHOWN NOT FOR PINDLE HITCH TRAILERS	
RELEASED: -		
APPROX. WEIGHT: 323# W/O AXLE		
MATERIAL: SEE PART DWGS.		
TOLERANCE UNLESS OTHERWISE STATED: X = +/- .12 XX = +/- .062 XXX = +/- .031 ANGLES = +/- .1°		
All of the information shown herein is the intellectual property of Cush Corp and is submitted only on a confidential basis. The recipient agrees that no disclosure of this information will be made to a third party without written consent of Cush Corp. This design protected by Cush patents or patents pending.		
SHEET 1 OF 4	SCALE: A-SIZE B-SIZE 1:8 D-SIZE 1:4	REV: PART/DRAWING NO: B CLC-25-005L

This drawing and any attachments are intended solely for customers of CUSH Corp. The information contained in this file is confidential in nature and provided from further use or disclosure under U.S. Patent 1,068,102; 1,131,113; U.S. Patent 1,199,991; and may be subject to attorney-client or other legal privilege. Your use or disclosure of this information for any purpose other than that intended by its issue to you or your company is strictly prohibited, and may subject you to fines and/or penalties under federal and state law. If you are not the intended recipient of this information, please DESTROY ALL COPIES RECEIVED and confirm destruction to Cush Corp via written notification.