

CLT "BigFoot" Specifications

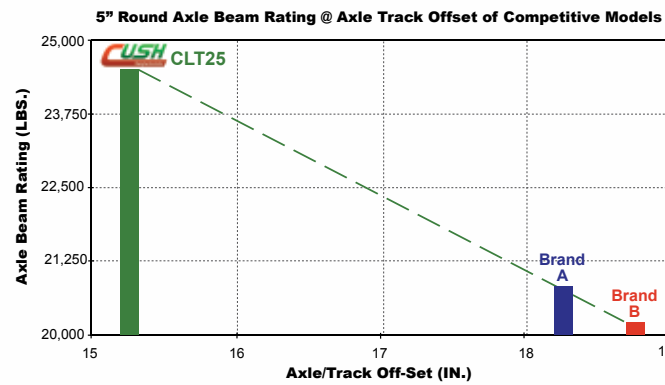

BigFoot Axle Advantage

Less track offset means you can use a lighter wall axle and have **greater axle beam capacity** than conventional models, also reducing the requirement for cambered axles.

25K Standard Axle

- 5" Round, beam and brake with ABS brackets
- 16.5" x 7" drum brakes
- 20.38" cam length, 28 spline
- 71.5" track with tapered spindles

Axle Options

You can supply your own axle or let Cush integrate one into your suspension. Cush offers a number of axle tracks, including 73", 77.5", 80" and 83". Choose a fully or partially dressed axle, with options such as disc brakes or 16.5" x 8.63" drum brakes. You can also choose parallel spindles or add an optional tire inflation system to improve your tire life and fuel mileage.

Weld-on Suspension Model	Ride Height (in)	Up Jounce (in)	Down Rebound (in)	Suspension Weight (Lbs.)	Unit Weight CLT-25 (Lbs.)
CLT_14	13.5	3.2	5.9	236	524
	14	3.7	4.9	236	524
	15	4.7	3.9	236	524
CLT_15	15	3.6	3.9	237	525
CLT_16	16	3.7	4.5	246	534
	17	4.7	3.5	246	534
CLT_17	17	3.6	3.5	247	535
CLT_19	19	3.6	4.5	259	547

Weight Notes: Suspension weights shown with straight sided weld-on hanger & does not include any front hanger support structure. Unit weights include integrated standard 71.5" track beam-and-brake axle with 16.5" x 7" brakes and 20.38" cams.

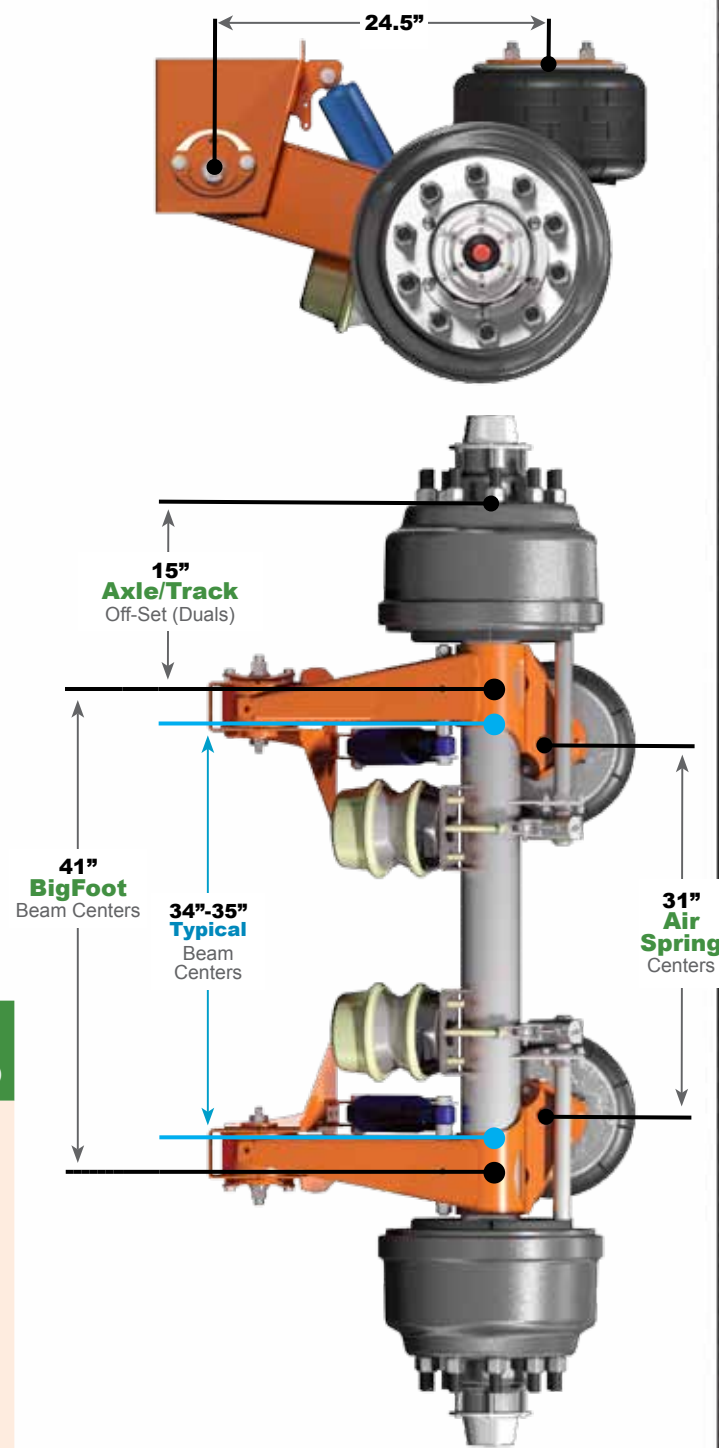

*Patent Pending
*Dimensions shown for 71.5" track axle



Full Solution Provider

The CLT is just one in Cush's comprehensive lineup of suspensions that enhance the way your vehicle performs. Cush offers a variety of **trailer air suspensions, trailer mechanical suspensions, truck lift axle products** and other parts and kits that give you a more competitive product for your money.



Giving the world a better ride!

I started Cush in 2000 because customers wanted a company willing to engineer and make special suspensions. Our **engineered-to-order** mounting configurations and innovative suspensions show that we're willing and able to put our customers first. We have grown because we listen to what you want from a suspension system that will help you build a more competitive trailer or truck.

Jason Klein - President, Cush Corp



WIDER IS BETTER!

Cush Corp
1001 Falconcrest Court
Nixa, MO 65714

Call Toll Free: 1.877.786.6247
Fax: 1.417.724.1239
Email: info@cushcorp.com



The CushLITE has a BigFoot.

When CushLITE was still in the planning stages, it had a code name: BigFoot. "BigFoot" because CushLITE suspensions feature the industry's **widest axle footprint**, improving axle capacity, axle bending stiffness, tire wear, axle tracking and road stability. We call it the BigFoot feature. You get all these improvements while allowing for a much **lighter weight** than competitive suspensions. The CLT features approximately an 18% increase in axle bending stiffness over the competition's integrated suspensions. The BigFoot feature effectively distributes the weight and grips the axle wider to reduce the burden on the axle, tires, shocks and your trailer.

25,000 lbs (11,340 kg) Capacity

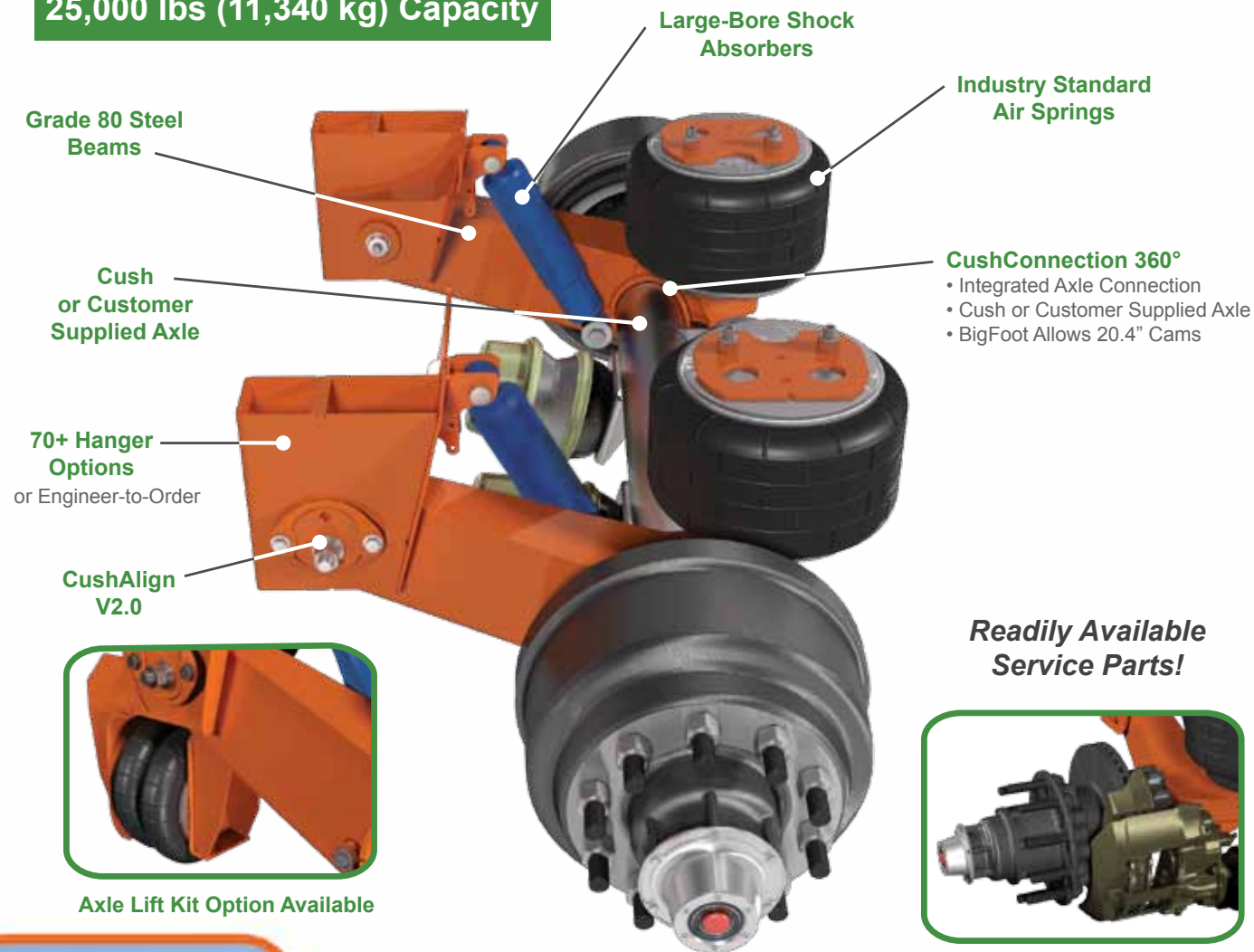

Readily Available Service Parts!



Disc Brake Option Available



Technology that Moves You

The CLT Employs Simple Concepts that Work.

The CLT beats the competition in the three most important aspects of trailer suspensions: it has a **lighter, more durable feel**; a **smoother ride** and **better stability** than similar suspensions. Each feature on the CLT contributes to its strength, so you know you're getting the best on all levels. The CushLITE is also available as a LowMount, as well as with options for mounting to slider subframes.



CushConnection360°



- Patent pending design is more **secure**
- **Reduces bending moment**, distributing the weight and avoiding any high stress points
- Adds another layer of protection at otherwise weaker connection areas
- Along with the Bigfoot feature, eliminates the need for cambered axles

CushAlign V2.0



- Quick positive axle alignment
- No welding or special tools required
- **Performance pivot hardware:**
 - AudiTorx® bolt
 - SecureLok™ nut
 - Eccentric adjustment
 - Dual wear washers
 - RingLock feature

Solid Bushing



- Solid bushing isn't fancy...it just works.
- Provides **better roll stability** than similar bushings with voids
- **Industry standard** replaceable bushing

Large-Bore Shock Absorbers



- Specifically tuned to the CLT
- Heavy duty for optimum performance
- Increase **suspension control**, improving your ride
- Industry standard replaceable shocks
- Optional nylon shock straps

Engineered-to-Order

Total Customization

Cush offers 70+ frame mounting options for flexibility, but if you still can't find what you need, Cush will make it for you. Don't settle for a one-size-fits-all suspension. Cush's **engineered-to-order** mounting configurations guarantee the right fit.



Multiple Hanger Options

- Weld-on straight sided winged or wingless standard hanger
- Weld-on tapered sided winged or wingless for welding to 4-inch wide frames
- Flat top bolt-on hangers for aluminum framed flatbed trailers
- Side-mount bolt-on hangers for aluminum framed tanker, grain or livestock trailers
- Optional finishes include plain, primer, soft coat or galvanized

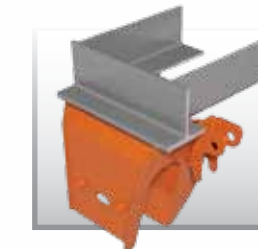
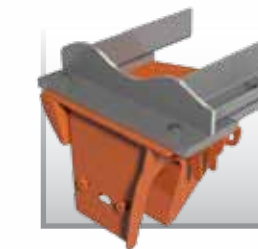
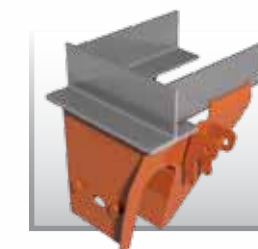
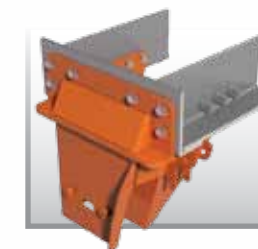

Hanger Support Options

- Winged front gusset
- Winged front gusset with tank mounts
- Front cross-member
- K-brace kit (bolt-on)
- Engineered-to-order bracing



Why Choose CushLITE?

Standard Features

- "BigFoot" mounting
- CushConnection 360°
- CushAlign V2.0
- Solid narrow bushing
- Integrated HCV mountings
- 13.5" to 19" ride heights
- Large-bore shocks

CushLITE suspensions combine **innovation** with **quality** to give you a truly unique suspension to fit your needs. The CLT is in a class of its own, with superior technology like the **CushConnection 360°** and the **CushAlign V2.0**, an easy-to-use alignment system, and Cush's simple but effective **solid bushing**. The CLT puts the driver in control. With **heavy duty shocks** that help control the suspension, brakes, and overall quality of ride, the CLT provides the smoothest possible drive stability to help **prolong tire life**.

Cush's easy-to-replace service parts are **industry standard** and can be purchased off the shelf, without the need for special orders. That means you can spend less time in the shop and more time on the road.



www.cushcorp.com



CUSH
Suspensions

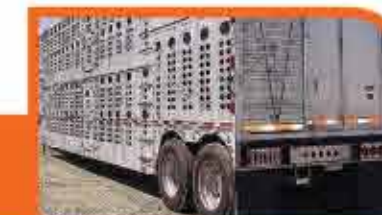

www.cushcorp.com